

**Order Number  
63811-4400**

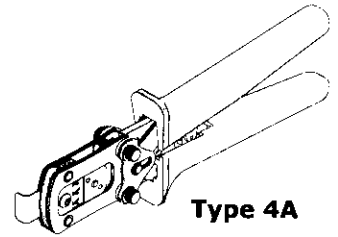

**Application Tooling Specification**



**FEATURES**

- A full-cycle ratcheting hand tool ensures complete crimps
- Ergonomically designed soft handles
- Precisely designed crimping profiles with simple contact positioning
- Easy handling due to outstanding force ratio
- This tool is IPC/WHMA-A-620 compliant
- Modular Crimp Head is removable and can be used in the Electric Crimp Machine (Order No. 63816-1900), accompanied by Crimp Adapter (Order No. 63816-1950)
- Can also be used in the Battery Powered Tool Order No. 63816-0270 (110 V) or 63816-0280 (220 V), accompanied by Crimp Adapter (Order No. 63816-1950)

**SCOPE**

**Products:** MX150L Crimp Terminals, 14-22 AWG.

Terminal Series No.	Terminal Order No.				Wire Size		Insulation Diameter Maximum		Strip Length	
	Loose		Reel		AWG	mm <sup>2</sup>	mm	In.	mm	In.
19417	19417-0047	19417-0053	19417-0011	19417-0029	14-16	2.00-1.27	2.87-3.53	.113-.139	4.20-5.00	.165-.197
	19417-0049		19417-0025	19417-0031						
	19417-0051		19417-0027	19417-0033						
	19417-0048	19417-0054	19417-0024	19417-0030	18-22	0.83-0.36	2.36-2.74	.093-.108	4.20-5.00	.165-.197
	19417-0050		19417-0026	19417-0032						
	19417-0052		19417-0028	19417-0034						
19420	19420-0009		19420-0001	19420-0007	14-16	2.00-1.27	2.87-3.53	.113-.139	4.20-5.00	.165-.197
	19420-0011		19420-0003							
	19420-0010		19420-0002	19420-0008	18-22	0.83-0.36	2.36-2.74	.093-.108	4.20-5.00	.165-.197
	19420-0012		19420-0004							

**DEFINITION OF TERMS**

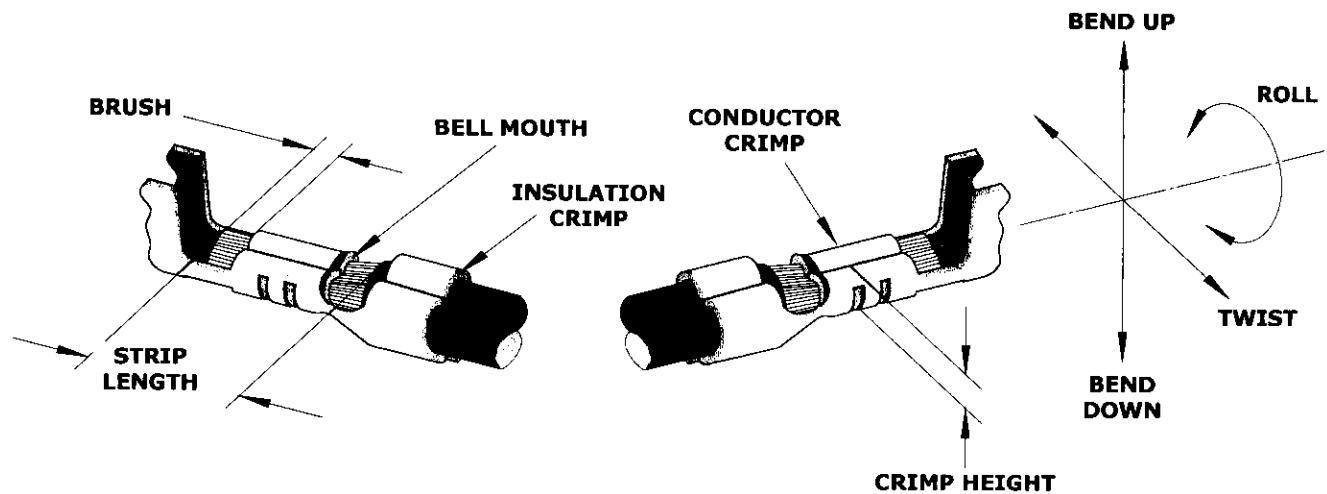

The above terminal drawing is a generic terminal representation. It is not an image of a terminal listed in the scope.

**CRIMP SPECIFICATION**

After crimping, the crimp profiles should measure the following (see notes on page 4):

Terminal Series No.	Bell Mouth		Conductor Brush		Bend Up	Bend Down	Twist	Roll
	mm	In.	mm	In.	Degree		Degree	
19417	0.25-1.25	.010-.049	0.15-0.65	.006-.026	5	5	4	8
19420	0.25-1.25	.010-.049	0.15-0.65	.006-.026	5	5	4	8

Terminal Series No.	Wire Size		Conductor Crimp Ref.				Insulation Crimp Ref.				Pull Force Minimum		Profile AWG	
			Height		Width		Height Maximum		Width					
	AWG	mm <sup>2</sup>	mm	In.	mm	In.	mm	In.	mm	In.	N	Lb.	18-22	14-16
19417	14	2.00	1.45-1.55	.057-.061	2.50	.098	3.50	.138	4.30	.169	222.6	50.00		X
	16	1.27	1.45-1.55	.057-.061	2.50	.098	3.50	.138	4.30	.169	133.5	30.00		X
	18	0.83	1.10-1.20	.043-.047	2.00	.079	3.50	.138	3.40	.134	89.0	20.00	X	
	20	0.83	1.10-1.20	.043-.047	2.00	.079	3.50	.138	3.40	.134	57.9	13.00	X	
	22	0.83	1.10-1.20	.043-.047	2.00	.079	3.50	.138	3.40	.134	35.6	8.00	X	
19420	14	2.00	1.45-1.55	.057-.061	2.50	.098	3.50	.138	4.30	.169	222.6	50.00		X
	16	1.27	1.45-1.55	.057-.061	2.50	.098	3.50	.138	4.30	.169	133.5	30.00		X
	18	0.83	1.10-1.20	.043-.047	2.00	.079	3.50	.138	3.40	.134	89.0	20.00	X	
	20	0.58	1.10-1.20	.043-.047	2.00	.079	3.50	.138	3.40	.134	57.9	13.00	X	
	22	0.36	1.10-1.20	.043-.047	2.00	.079	3.50	.138	3.40	.134	35.6	8.00	X	

**OPERATION**

Open the tool by squeezing the handles together. At the end of the closing stroke, the ratchet mechanism will release the handles, and the hand tool will spring open.

**Crimping Terminals**

1. Select the proper locator on the locator assembly for the proper terminal. The female locator is gray and is marked with an "F". The male locator is black and is marked with an "M".
2. To position the desired locator, pull up on the knurled pin and turn 180° till the locator fits snugly in the slot. See Figure 6.
3. Lift up on the wire stop blade.
4. Insert the terminal fully into the correct die profile and locator slot until the terminal is fully seated and stops.
5. Bring down the wire stop blade. Make sure the wire stop blade is fully seated on the terminal, behind the conductor grip section.
6. Slide the pre-stripped wire into the terminal. Make sure to aim the wire brush toward the tip point on the wire stop blade. See Figure 1.

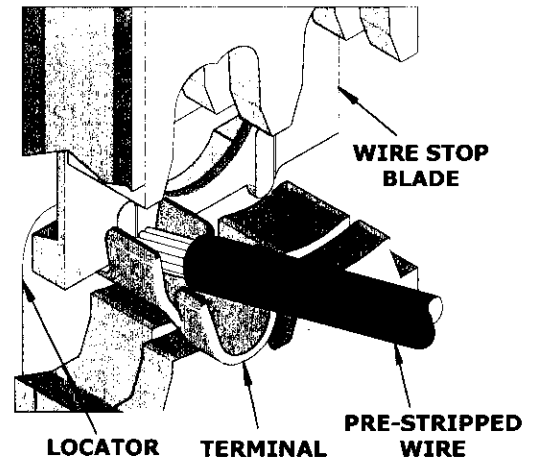
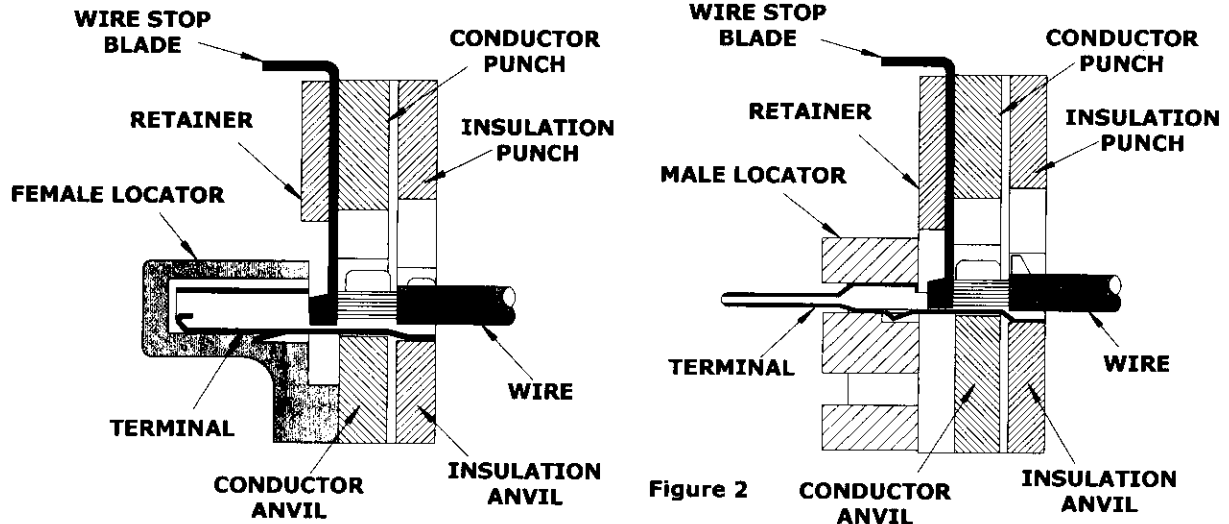

Figure 1

## Hand Crimp Tool for MX150L Crimp Terminals

- Align the wire so that it is parallel and sitting in the terminal. Maintain a light and constant pressure on the wire that is seated in the terminal at all times. Do not let go of the wire. Be sure to hold the wire and terminal in place until the terminal is fully crimped. See Figure 2.
- Close the tool until the ratchet releases.
- Lift up on the wire stop blade.
- Carefully remove the crimped terminal.



**Note:** The tamper-proof ratchet action will not release the tool until it has been fully closed.

**Note:** To maintain good brush control and a consistent bell mouth, the crimping instructions must be followed.

## MAINTENANCE

It is recommended that each operator of the tool be made aware of and responsible for the following maintenance steps:

- Remove dust, moisture and other contaminants with a clean brush or a soft, lint-free cloth.
- Do not use any abrasive materials that could damage the tool.
- Make certain all pins, pivot points and bearing surfaces are protected with a thin coat of high-quality machine oil. Do not oil excessively. The tool was engineered for durability, but like any other equipment, it needs cleaning and lubrication for a maximum service life of trouble-free crimping. Light oil (such as 30 weight automotive oil) used at the oil points every 5,000 crimps or every 3 months will significantly enhance the tool life.
- Wipe excess oil from the hand tool, particularly from the crimping area. Oil transferred from the crimping area onto certain terminations may affect the electrical characteristics of an application.
- When tool is not in use, keep the handles closed to prevent objects from becoming lodged in the crimping dies, and store the tool in a clean, dry area.

### Miscrimps or Jams

Should this tool ever become stuck or jammed in a partially closed position, **Do Not** force the handles open or closed. The tool will open easily by lifting the ratchet release lever. See Figure 6.

### Warranty

This tool is for electrical terminal crimping purposes only. This tool is made of the best quality materials. All vital components are long-life tested. All tools are warranted to be free of manufacturing defects for a period of 30 days. Should such a defect occur, Molex will repair or exchange the tool free of charge. This repair or exchange will not be applicable to altered, misused or damaged tools. This tool is designed for hand use only. Any clamping, fixturing or use of handle extensions voids this warranty.

**CAUTION:** Repetitive use of this tool should be avoided.

### CAUTIONS

1. Manually powered hand tools are intended for low-volume use or field repair. This tool is NOT intended for production use. Repetitive use of this tool should be avoided.
2. Insulated rubber handles are not protection against electrical shock.
3. Wear eye protection at all times.
4. Use only the Molex terminals specified for crimping with this tool.

**CAUTION:** Molex crimp specifications are valid only when used with Molex terminals and tooling.

### NOTES

1. This tool should only be used for the terminals and wire gauges specified on this sheet.
2. This tool is not adjustable for crimp height; however, crimp force is adjustable. See instructions above. Variations in tools, terminals, wire stranding and insulation types may affect crimp height.
3. This tool is intended for standard conductor sizes. It may not give good insulation crimp support for all insulation sizes.
4. Molex does not repair hand tools (see warranty above). The replacement parts listed are the only parts available for repair. If the handles or crimp tooling are damaged or worn, a new tool must be purchased.
5. Pull force should be used as the final criterion for an acceptable crimp. Pull force is measured with no influence from the insulation crimp. The insulation should be stripped long (.50") so the insulation grips on the terminal do not grip the wire insulation or the conductor. Refer to the Molex Quality Crimping Handbook (63800-0029) for additional information on crimping and crimp testing.
6. Molex does not certify crimp hand tools.

**WARNING:** NEVER operate, service, install or adjust this modular crimp head without proper instruction and without first reading and understanding the instructions in the proper manual or specification sheet. See chart below for the correct manual or specification sheet.

### APPLICATIONS FOR THE MODULAR CRIMP HEAD

**WARNING:** NEVER install tooling or service this tool while it is plugged into any power source. Disconnect the power by unplugging, or turn off the actuator from its power source.

**CAUTION:** Keep fingers away from the crimping area when operating this tool. It may cause severe injury.

**CAUTION:** Wear safety glasses when operating or servicing this tool.

Hand Crimp Tool for MX150L Crimp Terminals

Tool Order No.	Tool Description	Adapter Order No.	Adapter Description	Figure No.
63816-0270	Battery Power Tool (110 V)	63816-1950	Crimp Adapter	3
63816-0280	Battery Power Tool (220 V)	63816-1950	Crimp Adapter	3
63816-1900	Electric Crimp Machine	63816-1950	Crimp Adapter	4

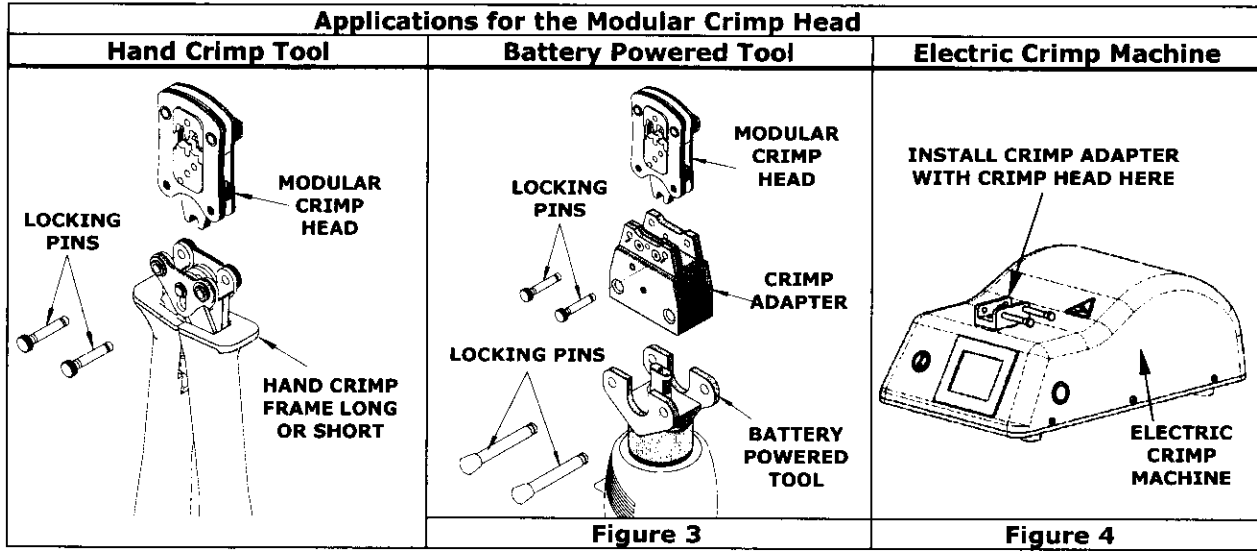

**PARTS LIST**

Hand Crimp Tool 63811-4400			
Item	Order Number	Description	Quantity
1	----	Hand Crimp Frame	1
2	63811-4475	Terminal Locator	1
3	63816-0001	Locking Pin	2
4	63600-0525	Handle Spring	1
5	63600-0520	Crimping Spring	2

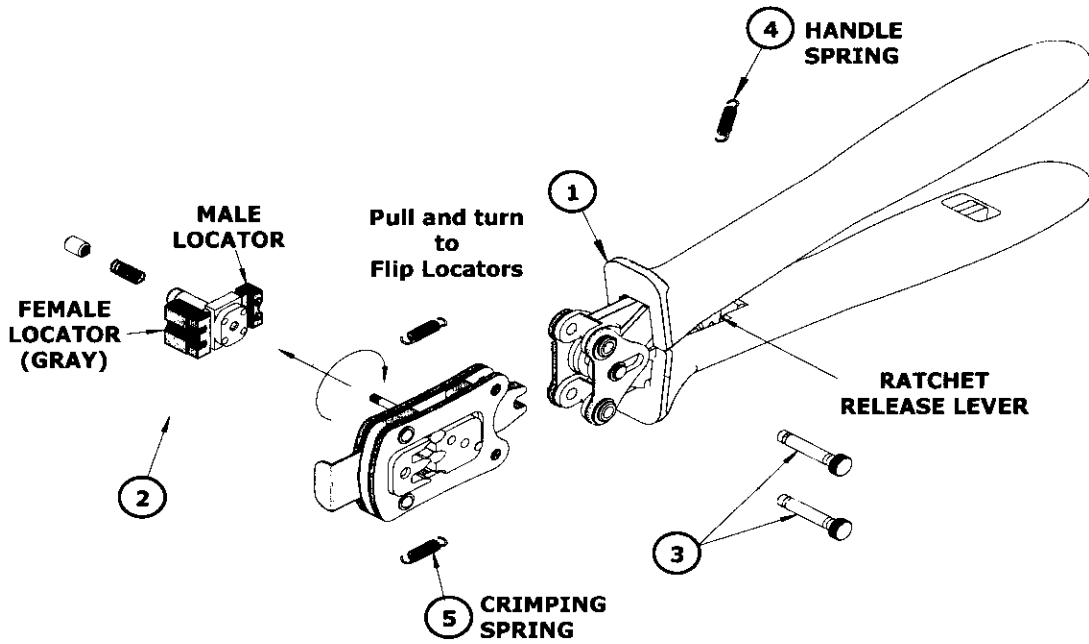

Figure 5

**Application Tooling Support**

**E-Mail:** [applicationtooling@molex.com](mailto:applicationtooling@molex.com)  
**Website:** [www.molex.com/applicationtooling](http://www.molex.com/applicationtooling)

Molex is a registered trademark of Molex, LLC in the United States of America and may be registered in other countries; all other trademarks listed herein belong to their respective owners.